

ARMANOV

Armanov Smart Controller for
Dillon Variable Speed Casefeeder

Instructions Manual



Armanov d.o.o.
Dobrave 3
1236 Trzin, Slovenija
Tel: +386 30 467 000
www.armanov.com

Assembly

Remove the see-trough controll panel and the motor cover panel from your Dillon Variable Case feeder by removing 6x 1/4" hex screws (fig. 1).

(Screw head is 1/4", same size as a standard screw bit holder)

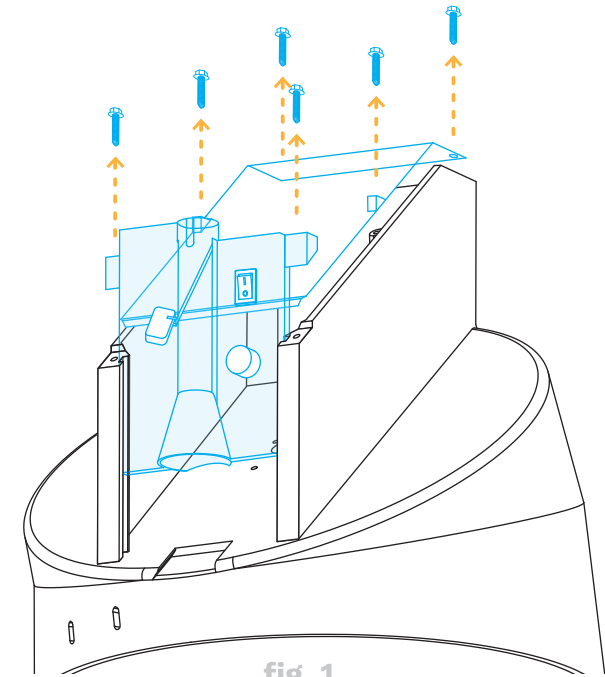

fig. 1

Disconnect the blue, red and yellow wires from the circuit board. Blue and yellow wire must remain attached to the motor! (fig. 2)

- 2x "click off" white connectors
- 3x wires: blue, red, yellow (green terminal with flathead screws)

Do not remove black wire. **

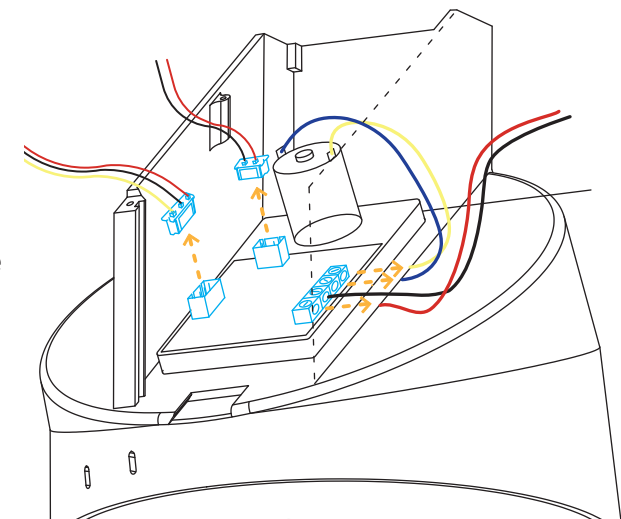

fig. 2

Cable connection

Before installing ASC, connect the motor cables to the ASC cables with supplied quick connect clips. (fig. 3)

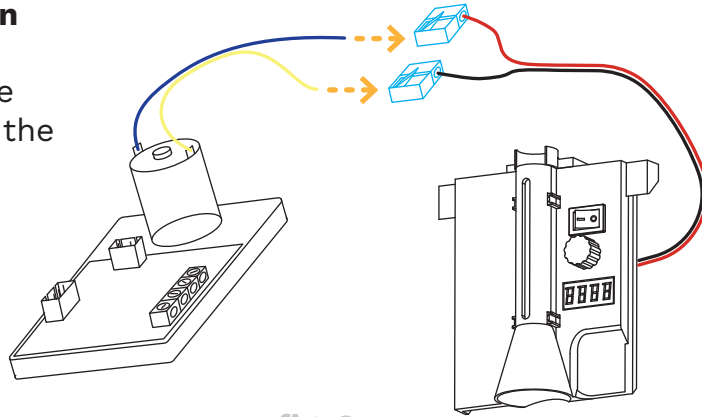

fig. 3

Connect wires:
Motor+(blue) to red wire on ASC
Motor-(yellow) to black wire on ASC

ASC installation

When wires are connected, slide the ASC in place of the original see-through control panel and reinstall the motor cover. Attach both with the 6 original screws. (fig. 4)

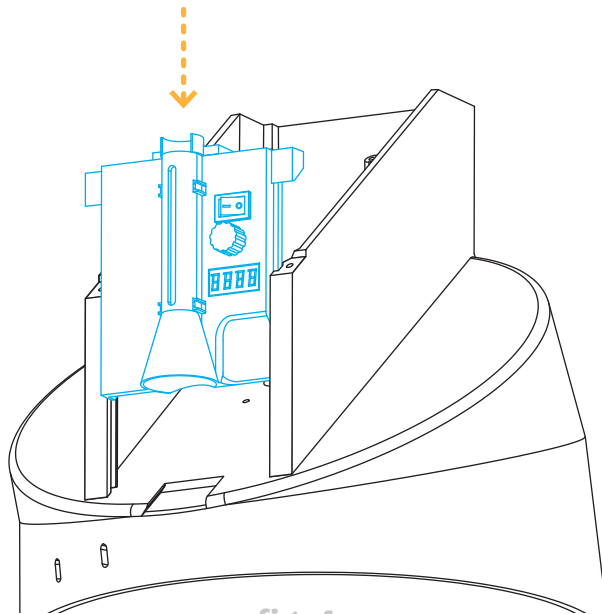

fig. 4

Power On

When installed in your casefeeder connect the original Dillon casefeeder power supply to the ASC unit. (fig. 5)

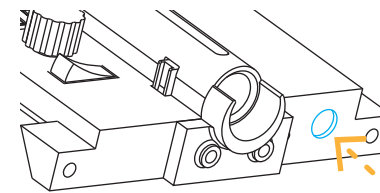

fig. 5

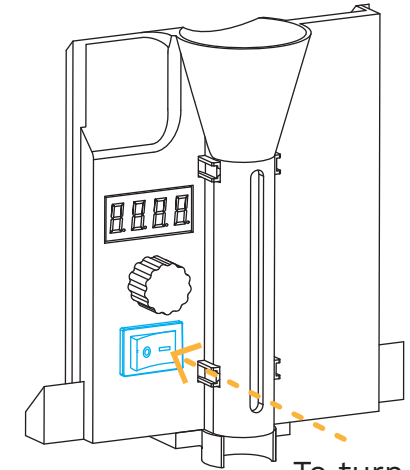

fig. 6

To turn the controller On/Off: press the 0/1 switch (fig. 6)

First startup (empty casefeeder)

On first Power ON, display will show auto, press the knob to allow the ASC to calibrate (all 9 speeds will cycle). When finished you can cycle through the values to see motor current draw for each speed. Turn OFF the ASC.

Motor digital clutch

The ASC has 5 levels of digital clutch sensitivity (P1-P5). It monitors motor current draw and, when a preprogrammed threshold is exceeded, it activates the auto reverse function.

Setup depends on how tightly your slip disc is adjusted on the case feeder shellplate. (more on ext page -->)

Digital clutch setup

Enter setup mode when the ASC is turned Off.*

Hold the knob (1), and power On the ASC (2). When screen reads CLUT, release it and confirm with press (3).

Scroll trough P1-P5 cluch programs by rotating the knob (4). Start with P2 or P3. Press the knob to confirm selection (5). (fig. 7)

After coosing P2 or P3, run the case feeder and simulate a jam using a case or tool. The ASC should trigger the auto reverse without causing the shellplate slip disc to slip.

- If the slip disc doesn't slip, you are set.
- If the slip disc slips, select a weaker program (P2 or P1). or adjust your slip disc tightness.
- You can use P4/P5 if needed on extra firm slip disc setting.

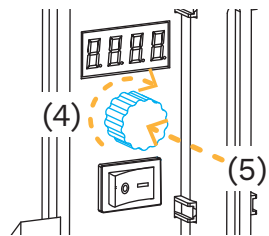
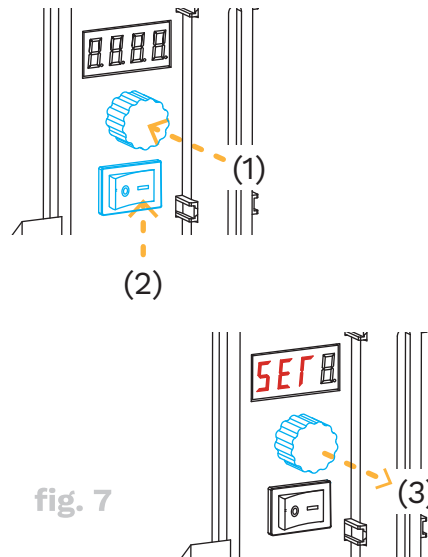

At power On the clutch program and software version will show.

Motor speed

When On, choose motor speed setting SPE1 - SPE9 by rotating the knob. The chosen speed saves automatically. (fig. 8)

fig. 8

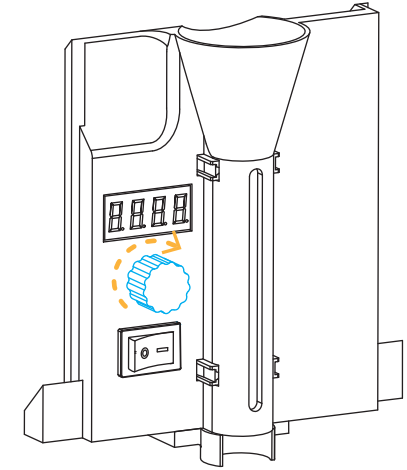

Pause / Run

To pause the casefeeder short press the knob once to pause, and again to run. (fig. 9)

fig. 9

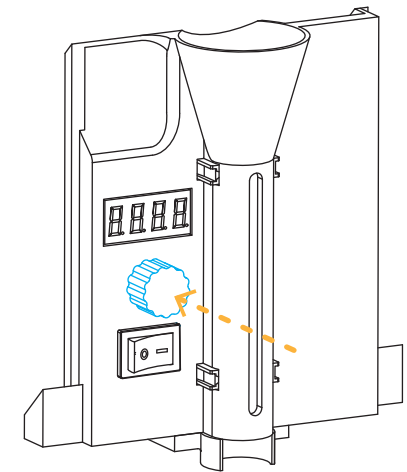

Count settings

Long press the knob to enter count setup (COUN). By rotating the knob you can choose (0) or a number (25 - 9900). Confirm with short press. (fig. 10)

SETTINGS:

- **0** (upcount with no auto stop)
- **25 - 9900** (count-down from chosen batch number to 0, with auto stop at 0)

Auto Reverse and Stop

If the ASC senses a jam it will auto reverse the motor to try to resolve the issue without user input. If this repeats 3 times in 10s, the system will stop and display will show error. User input is required., first turn Off the ASC, resolve the issue and turn the ASC On. Auto reverse resets automatically. (fig. 11)

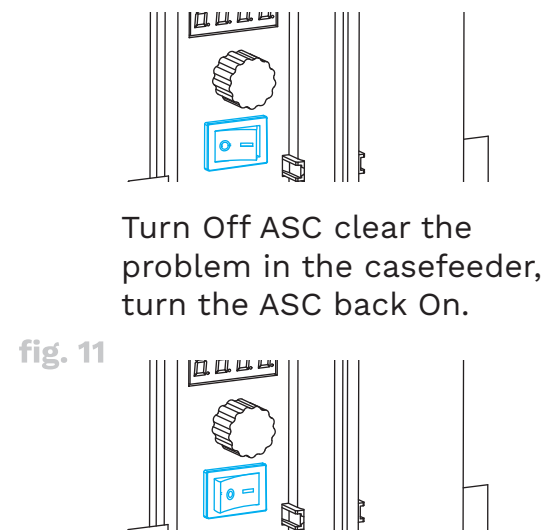
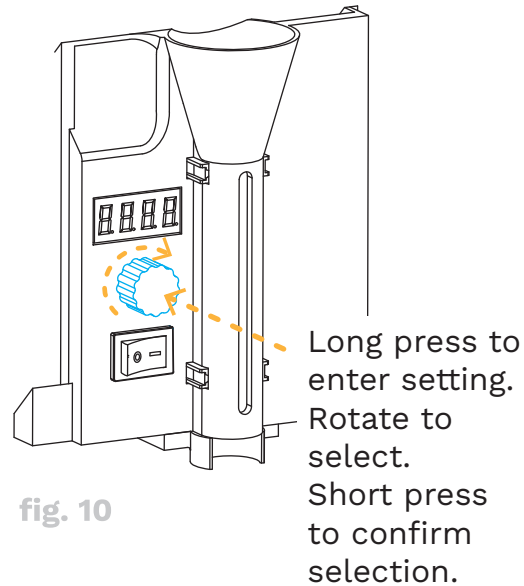

Auto idle stop

The ASC will auto pause if the sensors do not sense a case drop in more than 2min (120s). This prevents your casefeeder from running or powered on if left unchecked. This is also an indicator that your casefeeder is most likely empty.

*

After first power ON: Holding the knob and power On opens CLUT settings, if you keep holding the knob for about 3s you will enter AUTO calibration mode again. If you hold it further RST will open (factory reset). When you release the knob on a desired setting a confirmation press is required to enter the chosen menu (CLUT or AUTO or RST).

**

Black wire stays in place to ensure no short-circuit can occur if the old power plug is accidentally connected with the power adapter. The ASC must be connected to the Dillon power adapter through its built in power jack. (fig. 5)